



# HP 75000 SERIES B and C

## Eight-Channel Direct Input Signal Conditioning Plug-on HP E1501

---

### User's Manual

The HP E1501 manual also applies to HP E1413Bs as HP E1413 Option 11.

Enclosed is the User's Manual for the HP E1501 (HP E1413 Option 11 for HP E1413Bs) Signal Conditioning Plug-on. Insert this manual in your HP E1413/E1313 manual behind the "Signal Conditioning Plug-ons" divider.



Copyright © Hewlett-Packard Company, 1993, 1994, 1995, 1996



E1501-90001



# HP E1501

## Eight-Channel Direct Input Signal Conditioning Plug-on

---

### Introduction

The HP E1501 is the most basic Signal Conditioning Plug-on. The Direct Input SCP provides 8 hard wired paths that do not modify the input signal at all. The SCP provides input over-voltage detection and open transducer detection on each channel.

### About this Manual

This manual shows you how to control the Signal Conditioning Plug-on (SCP) using SCPI commands as well as Register-Based commands, and explains the capabilities of this SCP. The contents of this manual are:

- Installation ..... 3
- Field Wiring ..... 3
- Connecting To The Terminal Module ..... 4
- Identifying the Plug-on ..... 6
- Programming With SCPI Commands ..... 6
- Programming With Register Commands ..... 9
- Specifications ..... 11

### Installation

Installation for this Plug-on is common to several others and is covered in Chapter 1 of your HP E1413/E1313 manual.

### Field Wiring

Although field wiring is covered in Chapter 2 of your HP E1413/E1313 manual, a special consideration for the Direct Input SCP is that a channel input pair must have a return path to guard or ground. NanoAmp currents sourced from the HP E1413's A/D could cause inputs left floating (or isolated) to exceed the input protection trip point. When using isolated thermocouples, connect the shield to thermocouple low as close to the thermocouple junction as possible. The other end of the shield should be

connected to guard or ground. See “Preferred Signal Connections” in the main manual.

## Connecting To The Terminal Module

This section shows how to make connections to the Terminal Module.

The SCP connections for the Terminal Modules are shown on the stick-on labels that came with the SCP. Use the appropriate label for the type of Terminal Module you have. The connections and appropriate stickers are as follows:

- For HP E1413C and above Terminal Modules, use stickers for HP E1501 SCPs. The connections are shown in Figure 1.
- For HP E1313 Terminal Modules, use stickers for HP E1501 SCPs. The connections are shown in Figures 2 and 3.
- For HP E1413B and below Terminal Modules, use stickers for HP E1413 Option 11 SCPs. The connections are shown in Figure 4.

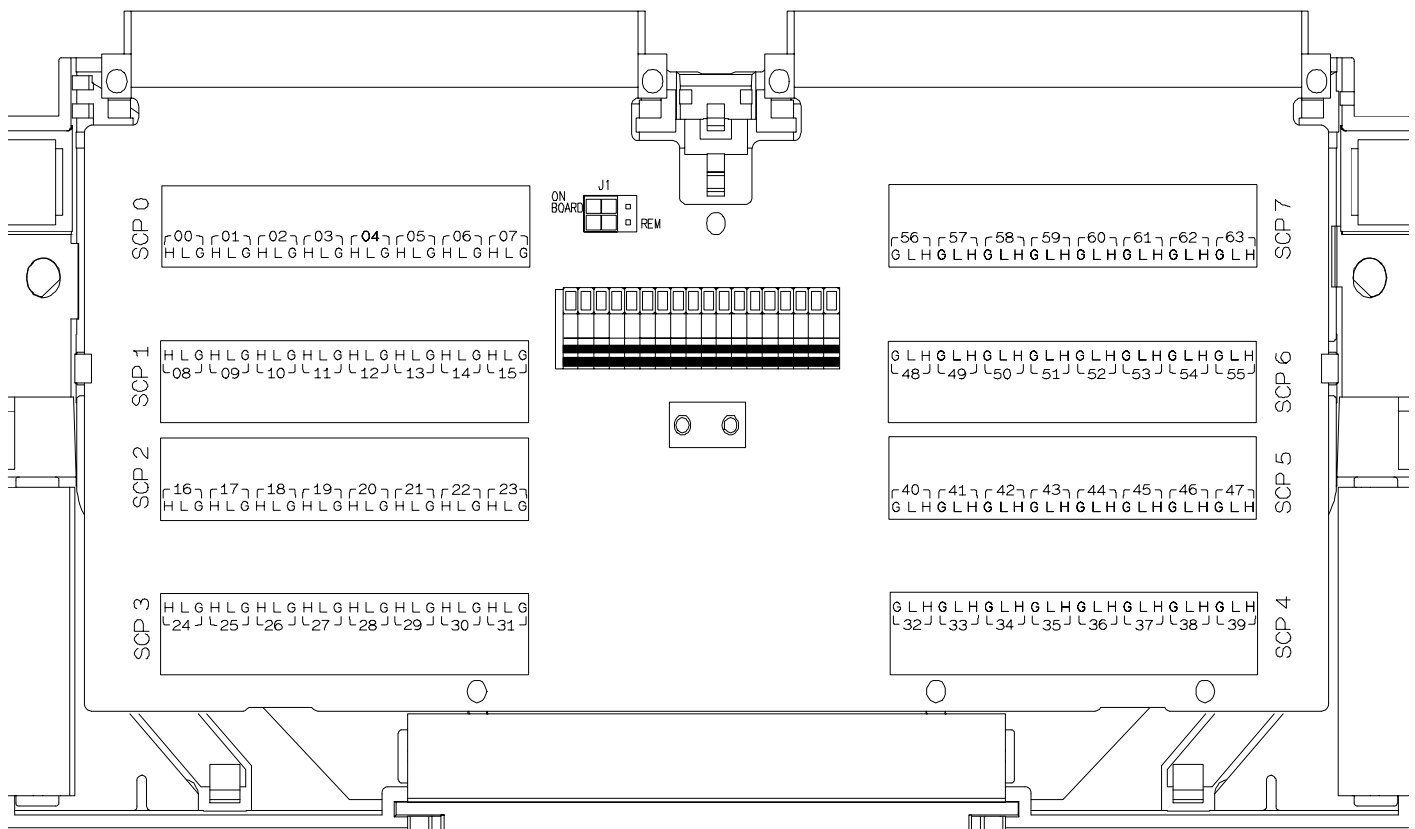
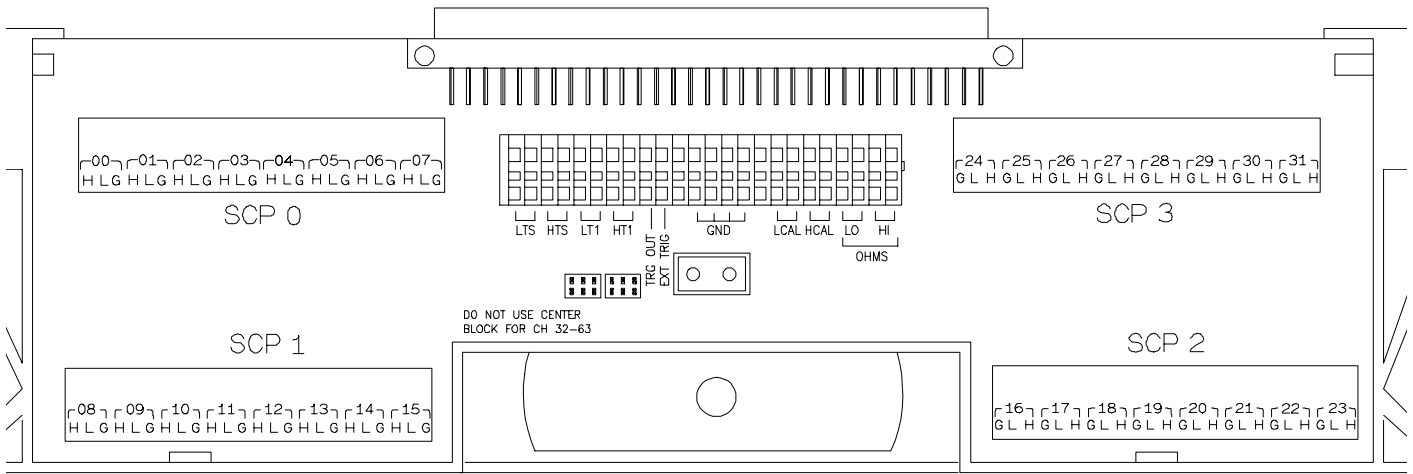
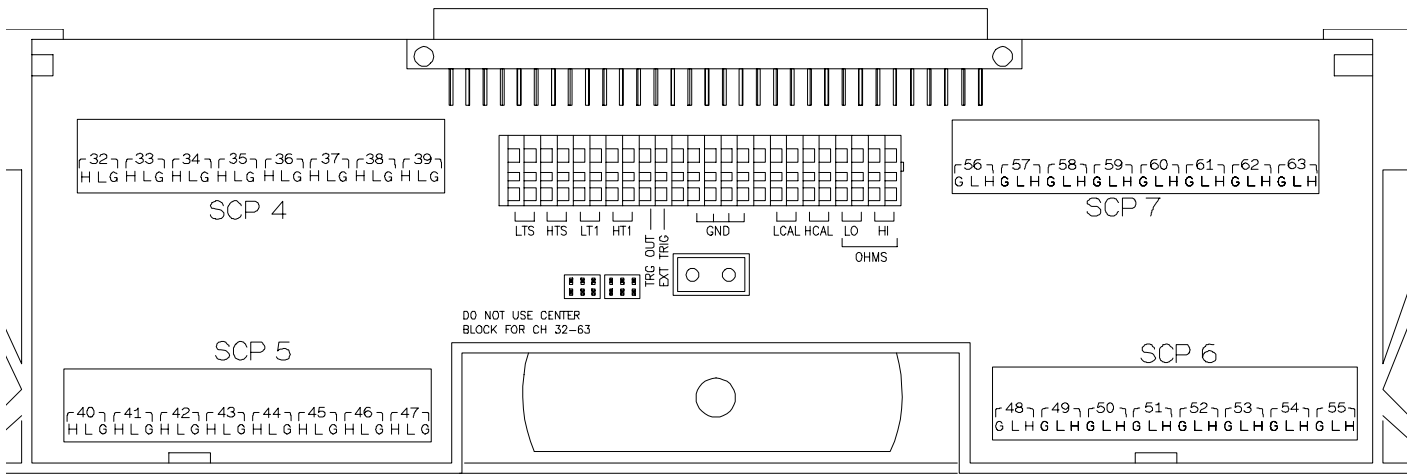

Figure 1 HP E1501 C-Size Terminal Module Connections



**Figure 2 HP E1501 B-size Terminal Module Connections (Ch 00-31)**



**Figure 3 HP E1501 B-size Terminal Module Connections (Ch 32-63)**

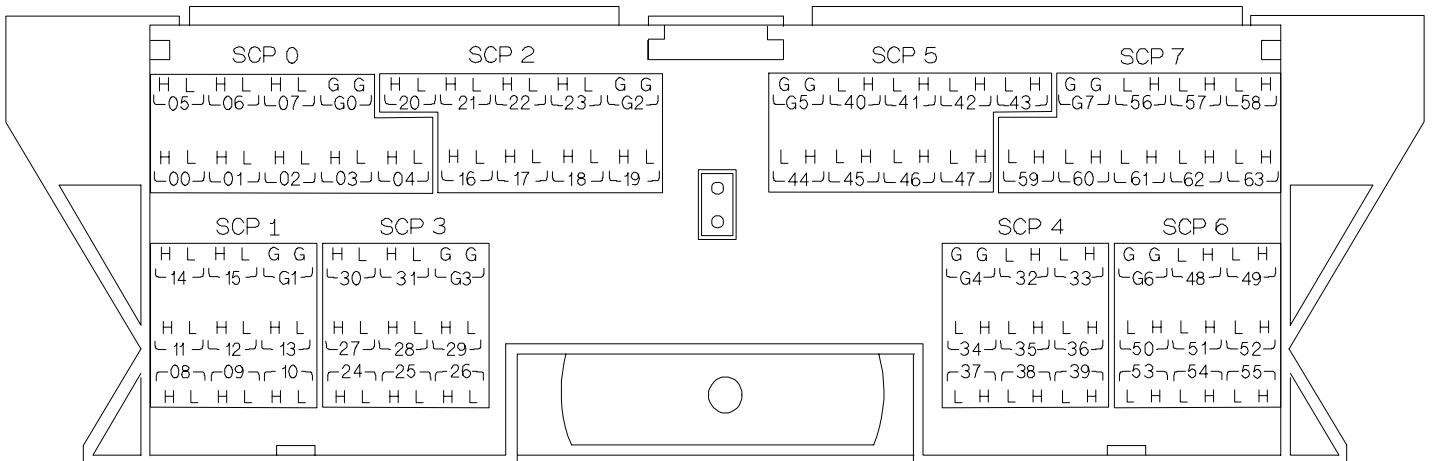

**Figure 4 HP E1413 Option 11 Terminal Module Connections**

## Identifying the Plug-on

You'll find the HP part number on the connector side of the SCP to the left of the serial number bar code. For the HP E1501, the part number is : E1413-63511

## Programming With SCPI Commands

The SCPI commands shown here are covered in Chapters 3 and 5 of your HP E1413/E1313 manual. This section will relate those commands to the parameter values which are specific to this Plug-on.

### Checking the ID of the SCP

To verify the SCP type(s) installed on the HP E1413/E1313 use the `SYSTem:CTYPe? (@<channel>)` command.

- The *channel* parameter specifies a single channel in the channel range covered by the SCP of interest. The first channel number for each of the eight SCP positions are; 0,8,16,24,32,40,48, and 56.

The value returned for the SCP in an HP E1413B is:

```
HEWLETT-PACKARD,E1413 Opt 11 8-Channel Straight-Through SCP,0,0
```

The value returned for the SCP in an HP E1413C/E1313A is:

```
HEWLETT-PACKARD,E1501 8-Channel Straight-Through SCP,0,0
```

To determine the type of SCP installed on channels 0 through 7 send

```
SYST:CTYP? (@100)           query SCP type @ ch 0
enter statement here         enter response string
```

### Querying the Filter Cutoff Frequency

While the Direct Input SCP does not provide any filtering, the cutoff frequency can be queried. Response to this query will always be 0 (zero).

To query any channel for its cutoff frequency use the `INPut:FILTer[:LPASs]:FREQuency? (@<channel>)` command. The `INP:FILT:FREQ?` command returns the numeric cutoff value currently set for the channel specified.

- The *channel* parameter must specify a single channel.

To query the cutoff frequency of channel 6 send

```
INP:FILT:FREQ? (@106)           query channel 6  
enter statement here
```

## Querying the Filter State

While the Direct Input SCP does not provide any filtering, the state of the filter can be queried. Response to this query will always be 0 (zero). To query any channel to determine if it is enabled or disabled use the INPut:FILTer[:LPASs][:STATe]? (@<channel>) command. The INP:FILT? command returns a 0 if the channel is OFF or a 1 if the channel is ON.

- The *channel* parameter must specify a single channel.

To query the filter state of channel 2 send

```
INP:FILT? (@102)                query channel 2  
enter statement here
```

## Querying the Channel Gain

While the Direct Input SCP does not provide amplifiers, the channel gain can be queried. Response to this query will always be 1. To query any channel to determine its gain setting use the INPut:GAIN? (@<channel>) command. The INP:GAIN? command returns the current gain value for the specified channel.

- The channel parameter must specify a single channel.

To query the gain setting of channel 8 send

```
INP:GAIN? (@108)                query channel 8  
enter statement here
```

## Detecting Open Transducers

This SCP provides a method to detect open transducers. When Open Transducer Detect (OTD) is enabled, the SCP injects a small current into the HIGH and LOW input of each channel. The polarity of the current pulls the HIGH inputs toward +17 volts and the LOW inputs towards -17 volts. If a transducer is open, measuring that channel will return an over-voltage condition. OTD is available on a per SCP basis. All eight channels of an SCP are enabled or disabled together. See Figure 8 for a simplified schematic diagram of the OTD circuit.

---

**NOTE**

When OTD is enabled, the inputs have up to  $0.2\mu\text{A}$  injected into them. If this current will adversely affect your measurement, but you still want to check for open transducers, you can enable OTD, make a single scan, check the CVT for bad measurements, then disable OTD and make your regular measurement scans. The specifications apply only when OTD is off.

---

To enable or disable Open Transducer Detection, use the DIAGnostic:OTDetect <enable>, (@<ch\_list>) command.

- The *enable* parameter can specify ON or OFF
- An SCP is addressed when the *ch\_list* parameter specifies a channel number contained on the SCP. The first channel on each SCP is:  
0, 8, 16, 24, 32, 40, 48, and 56

To enable Open Transducer Detection on all channels on SCPs 1 and 3:

DIAG:OTD ON, (@100,116) *0 is on SCP 1 and 16 is on SCP3*

To disable Open Transducer Detection on all channels on SCPs 1 and 3:

DIAG:OTD OFF, (@100,116)

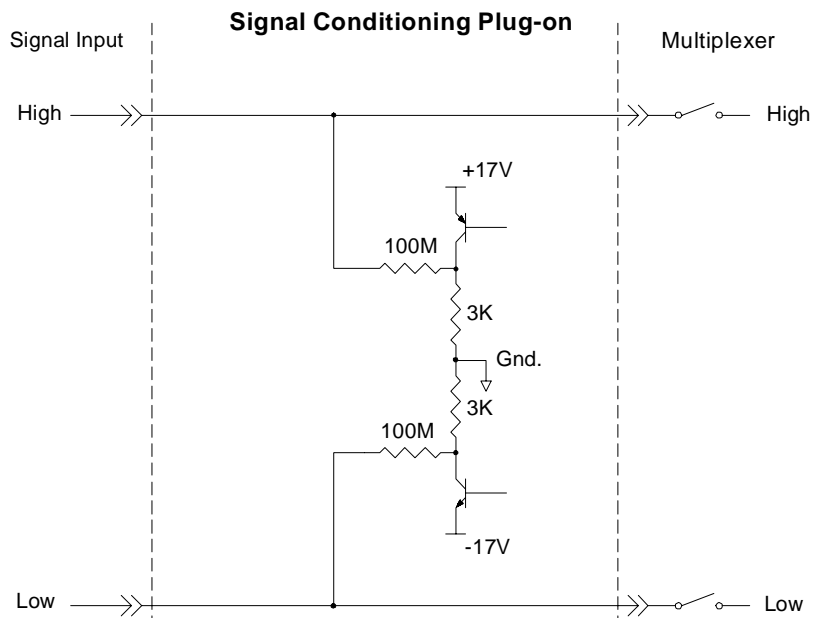

**Figure 5 Open Transducer Detect Circuit**



# Register Based Programming

The register-based commands shown here are covered in Appendix D of the HP E1413/E1313 manual. You should read that section first to become familiar with accessing registers and executing Register-Based Commands. This section will relate those commands to the parameter values which are specific to this Plug-on.

When Register Programming an SCP most communication is through the Signal Conditioning Bus. For that you will use the Register Commands:

SCBWRITE <regaddr> <regvalue>  
and  
SCBREAD? <regaddr>

## HP E1501 Register Map

Read (returned value)	Write( <regvalue>)	SCP Register	<regaddr> Value
SCP ID (2020 <sub>16</sub> )		Whole SCP Reg 0	00ppp000000 <sub>2</sub>

ppp=Plug-on  
ccc=SCP channel

In addition you will access bits in the Card Control register to control Open Transducer Detection.

## Checking ID of SCP

To query an SCP for its ID value, write the following value to Parameter Register 1:

$$(SCP\ number) \times 40_{16}$$

Then write the opcode for SCBREAD? (0800<sub>16</sub>) to the Command Register. The ID value will be written to the Query Response Register.

## Detecting Open Transducers

Open Transducer Detection (OTD) is controlled by bits in the Card Control Register. For more information on OTD see Figure 1.

### Card Control Register (Base + 12<sub>16</sub>)

15	14	14-13	12	11	10-8	7-0
PSI Pwr Reset	FIFO Mode	unused	FIFO Clear	VPPEN	A24 Window	Open Transducer Detect

Writing a one (1) to a bit enables open transducer detect on that signal conditioning module. Writing a zero (0) to a bit disables open transducer detect. See following table.

Bit 7	Bit 6	Bit 5	Bit 4	Bit 3	Bit 2	Bit 1	Bit 0
SCP 7	SCP 6	SCP 5	SCP 4	SCP 3	SCP 2	SCP 1	SCP 0

# Specifications

These specifications for the HP E1501 reflect the combined performance of the HP E1413/E1313 and the Direct Input Signal Conditioning Plug-on. These specifications are not to be added to those presented in the HP E1413/E1313 User's Manual.

## General Specifications

---

### Measurement ranges

DC Volts	(Opt 11) $\pm 62.5\text{mV}$ to $\pm 16\text{V}$ Full Scale
Temperature	Thermocouples - $-200$ to $+1700$ °C Thermistors - (Opt 15 required) $-80$ to $+160$ °C RTD's - (Opt 15 required) $-200$ to $+850$ °C
Resistance	(Opt 15 with opt 11) 512 ohms to 131 Kohms FS
Strain	25,000 $\mu\epsilon$ or limit of linear range of strain gage

---

<b>Maximum input voltage</b> (Normal mode plus common mode)	Operating: $< \pm 16$ V peak    Damage level: $> \pm 42$ V peak
--	---

---

<b>Maximum common mode voltage</b>	Operating: $< \pm 16$ V peak    Damage level: $> \pm 42$ V peak
------------------------------------	---

---

<b>Common mode rejection</b>	0 to 60Hz -105dB
------------------------------	------------------

---

<b>Input impedance</b>	greater than 100 Mohm differential
------------------------	------------------------------------

---

<b>Maximum tare cal offset</b>	(Maximum tare offset depends on A/D range and SCP gain)
--------------------------------	---

A/D range $\pm$ V F.Scale	16	4	1	0.25	0.0625
Max Offset	3.2213	.82101	.23061	.07581	.03792

**Measurement accuracy  
DC Volts**

(90 days) 23°C ±1°C (with \*CAL? done after 1 hr warm up and CAL:ZERO? within 5 min.). If autoranging is ON, add ±.02% FS to accuracy specifications.  
**For E1313, multiply Noise Spec. by 1.4.**

A/D range ±V F.Scale	Linearity % of reading	Offset Error	Noise 3 sigma	Noise* 3 sigma
.0625	0.01%	5.3 μV	18 μV	8 μV
.25	0.01%	10.3 μV	45 μV	24 μV
1	0.01%	31 μV	110 μV	90 μV
4	0.01%	122 μV	450 μV	366 μV
16	0.01%	488 μV	1.8 mV	1.5 mV

\* [SENSe:]FILTeR[:LPASs][:STATe] ON (max scan rate - 100 rdgs/sec/channel)

Temperature Coefficients: Gain - 10ppm/°C. Offset - (0 - 40°C) .14μV/°C, (40 - 55°C) .8μV+.38μV/°C

**Measurement accuracy  
Temperature**

(90 days) 23°C ±1°C (with \*CAL? done after 1 hr warm up and CAL:ZERO? within 5 min.). If autoranging is ON, add ±.02% FS to accuracy specifications.

(simplified specifications, see temperature accuracy graphs in HP E1413/E1313 manual for details)

The temperature accuracy specifications include instrument and firmware linearization errors. The linearization algorithm used is based on the IPTS-68(78) standard transducer curves. Add your transducer accuracy to determine total measurement error.

**Thermocouples**

<b>Type E</b>	A/D Filter	-200 to 0 °C	0 to 200 °C	200 to 400 °C	400 to 800 °C
	OFF ON*	2.25°C 1.65°C	0.37°C 0.22°C	0.27°C 0.15°C	0.25°C 0.15°C
<b>Type EEXtended</b>	A/D Filter	-200 to 0 °C	0 to 200 °C	200 to 800 °C	800 to 1000 °C
	OFF ON*	13.3°C 12.7°C	0.70°C 0.40°C	0.30°C 0.20°C	0.60°C 0.30°C
<b>Type J</b>	A/D Filter	-200 to 0 °C	0 to 200 °C	200 to 600 °C	600 to 775 °C
	OFF ON*	2.10°C 1.75°C	0.45°C 0.25°C	0.35°C 0.20°C	0.35°C 0.20°C
<b>Type K</b>	A/D Filter	-200 to 0 °C	0 to 400 °C	400 to 800 °C	800 to 1400°C
	OFF ON*	3.50°C 3.10°C	0.60°C 0.30°C	0.50°C 0.25°C	0.60°C 0.35°C
<b>Type R</b>	A/D Filter	0 to 100 °C	100 to 200 °C	200 to 600 °C	600 to 1000 °C
	OFF ON*	4.25°C 2.60°C	2.75°C 1.65°C	2.25°C 1.20°C	1.70°C 0.90°C

\* [SENSe:]FILTeR[:LPASs][:STATe] ON (max scan rate - 100 rdgs/sec/channel)

**Measurement accuracy  
Temperature (cont.)**

(simplified specifications, see temperature accuracy graphs in HP E1413/E1313 manual for details)

**Thermocouples (cont.)**

<b>Type S</b>	A/D Filter	0 to 100 °C	100 to 200 °C	200 to 800 °C	800 to 1750 °C
---------------	------------	-------------	---------------	---------------	----------------

	OFF	5.50°C	3.50°C	2.50°C	1.80°C
	ON*	4.00°C	2.30°C	1.50°C	0.90°C
<b>Type T</b>	A/D Filter	-200 to -100°C	-100 to 0 °C	0 to 200 °C	200 to 400 °C
	OFF	2.38°C	0.80°C	0.55°C	0.38°C
	ON*	1.78°C	0.50°C	0.30°C	0.20°C

**5KΩ Reference Thermistor**

A/D Filter	-10 to 65 °C	65 to 85 °C
OFF	0.012°C	0.016°C
ON*	0.0095°C	0.0100°C

**100Ω Reference RTD**

A/D Filter	-125 to 75°C
OFF	0.40°C
ON*	0.21°C

**100Ω RTD**

A/D Filter	-200 to 75 °C	75 to 300 °C	300 to 600 °C	600 to 970 °C
OFF	0.12°C	0.28°C	0.35°C	0.45°C
ON*	0.07°C	0.18°C	0.25°C	0.36°C

**2252Ω Thermistor**

A/D Filter	0 to 30 °C	30 to 70 °C	70 to 80 °C	80 to 100 °C
OFF	0.012°C	0.013°C	0.012°C	0.019°C
ON*	0.010°C	0.012°C	0.008°C	0.013°C

**5KΩ Thermistor**

A/D Filter	0 to 30 °C	30 to 70 °C	70 to 85 °C
OFF	0.014°C	0.020°C	0.028°C
ON*	0.011°C	0.014°C	0.019°C

**10KΩ Thermistor**

A/D Filter	0 to 30 °C	30 to 60 °C	60 to 90 °C	90 to 115 °C
OFF	0.015°C	0.020°C	0.023°C	0.035°C
ON*	0.013°C	0.014°C	0.017°C	0.023°C

*Notes*

---